



ITALIAN OUTDOOR



—

## VELE

Vele ombreggianti / *Shading sails*  
Voiles d'ombrage / *Sonnensegel*



# VELE

## R300/R310/R320

Vele ombreggianti con sistema brevettato di tensionamento del telo integrato nel montante inclinato, regolato da un automatismo con molle a gas. Montante con registro micrometrico dell'inclinazione. Tessuto in DACRON o TEMPOTESTAR.

*Shading sails with tensioned cloth patented system, with gas springs inserted in frontal inclined pole. Micrometric adjustment for the inclination in frontal pole. DACRON or TEMPOTESTAR fabric.*

Voiles ombrageant avec système breveté de tension de la toile intégré dans le montant incliné, réglé par un automatisme avec ressorts à gaz. Montant avec registre micrométrique de l'inclinaison. Tissu en DACRON ou TEMPOTESTAR.

*Sonnensegel mit patentiertem System zur Bespannung des Tuchs, das in die geneigte Stütze integriert ist und über eine Automatik mit Gasfedern reguliert wird. Pfosten mit mikrometrischer Einstellung der Neigung. Gewebe aus DACRON oder TEMPOTESTAR.*

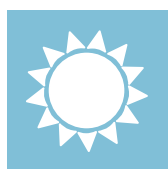

Protezione solare  
*Sun protection*  
Protection du soleil  
*Sonnenschutz*



Meccanismo di trazione brevettato  
*Patented traction system*  
Système de traction breveté  
*Patentiertes Spannungssysteme*



# VELA BASIC R300

Modulo singolo con  
1 piantana frontale  
+ 1 motore  
BT PERGOMOTOR.

*Single form with  
1 frontal pole  
+ 1 motor  
BT PERGOMOTOR.*

Module simple avec  
1 poteau frontal  
+ 1 moteur  
BT PERGOMOTOR.

*Einzelmodul mit  
1 vorderen Stütze  
+ 1 Motor  
BT PERGOMOTOR.*

## DIMENSIONI / DIMENSIONS DIMENSIONS / ABMESSUNGEN

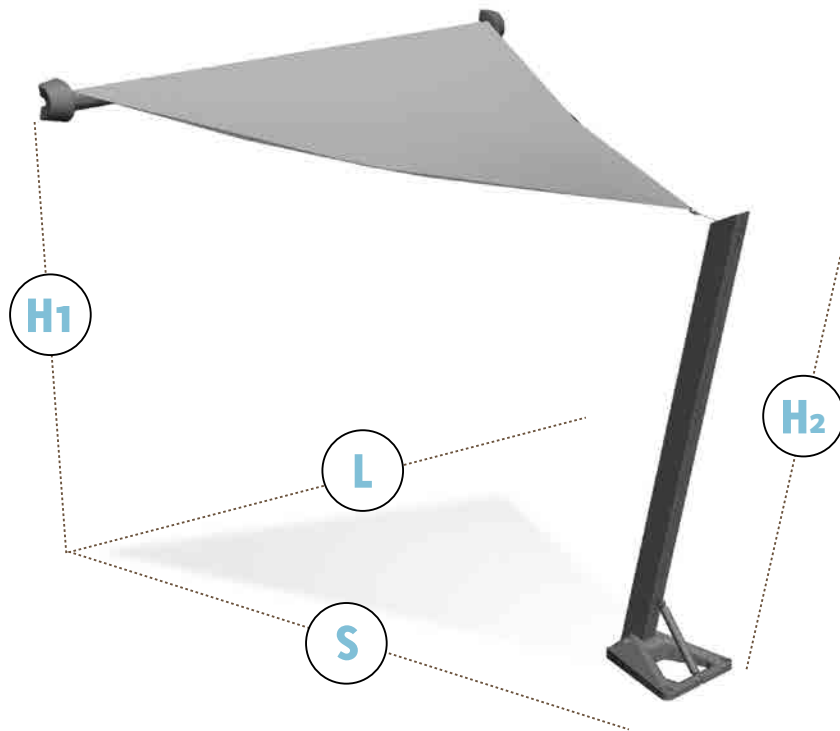

**(L)**

Larghezza / Width  
Largeur / Breite:  
100 >>> 600 cm.

**(S)**

Sporgenza / Projection  
Avancée / Ausladung:  
100 >>> 600 cm.

**(H1)**

Altezza posteriore  
Back height  
Hauteur arrière  
Hintere Höhe

**(H2)**

Altezza frontale  
Frontal height  
Hauteur frontale  
Vordere Höhe:  
220 >>> 300 cm.



## VELA BASIC R300

—  
Vela ombreggiante  
*Shading sail*  
Voile d'ombrage  
*Sonnensegel*



# VELA CUBE R310

Modulo singolo con  
2 piantane frontali  
+ 1 motore BT  
PERGOMOTOR.

*Single form with  
2 frontal poles  
+ 1 motor  
BT PERGOMOTOR.*

Module simple avec  
2 poteaux frontaux  
+ 1 moteur BT  
PERGOMOTOR.

*Einzelmodul mit  
2 vorderen Stützen  
+ 1 Motor BT  
PERGOMOTOR.*

## DIMENSIONI / DIMENSIONS DIMENSIONS / ABMESSUNGEN

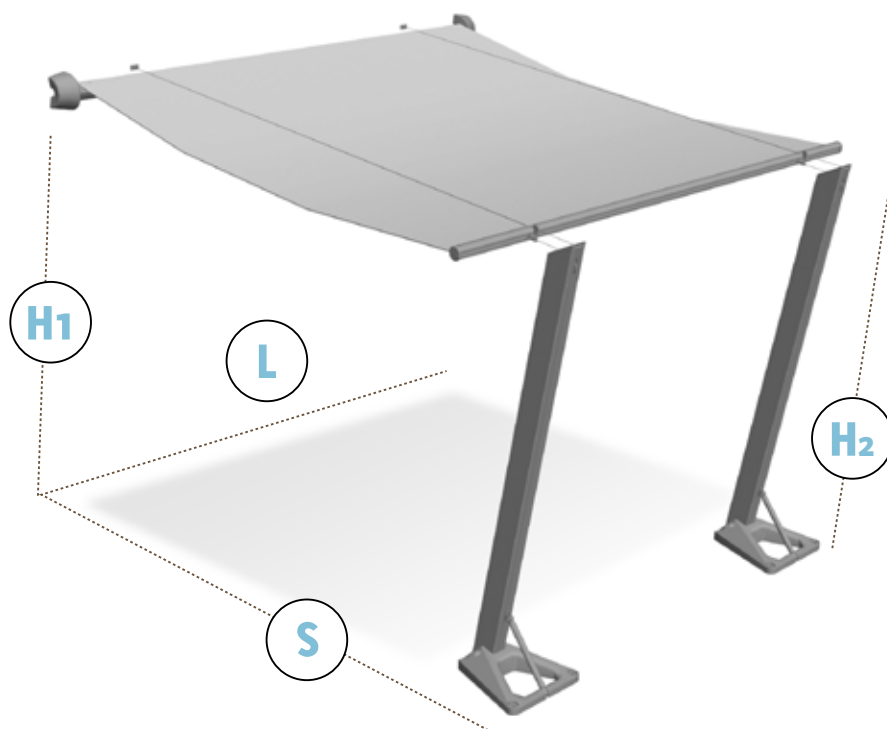

**(L)**

Larghezza / Width  
Largeur / Breite:

150 >>> 500 cm.

**(S)**

Sporgenza / Projection  
Avancée / Ausladung:

100 >>> 500 cm.

**(H1)**

Altezza posteriore  
Back height  
Hauteur arrière  
Hintere Höhe

**(H2)**

Altezza frontale  
Frontal height  
Hauteur frontale  
Vordere Höhe:

220 >>> 300 cm.





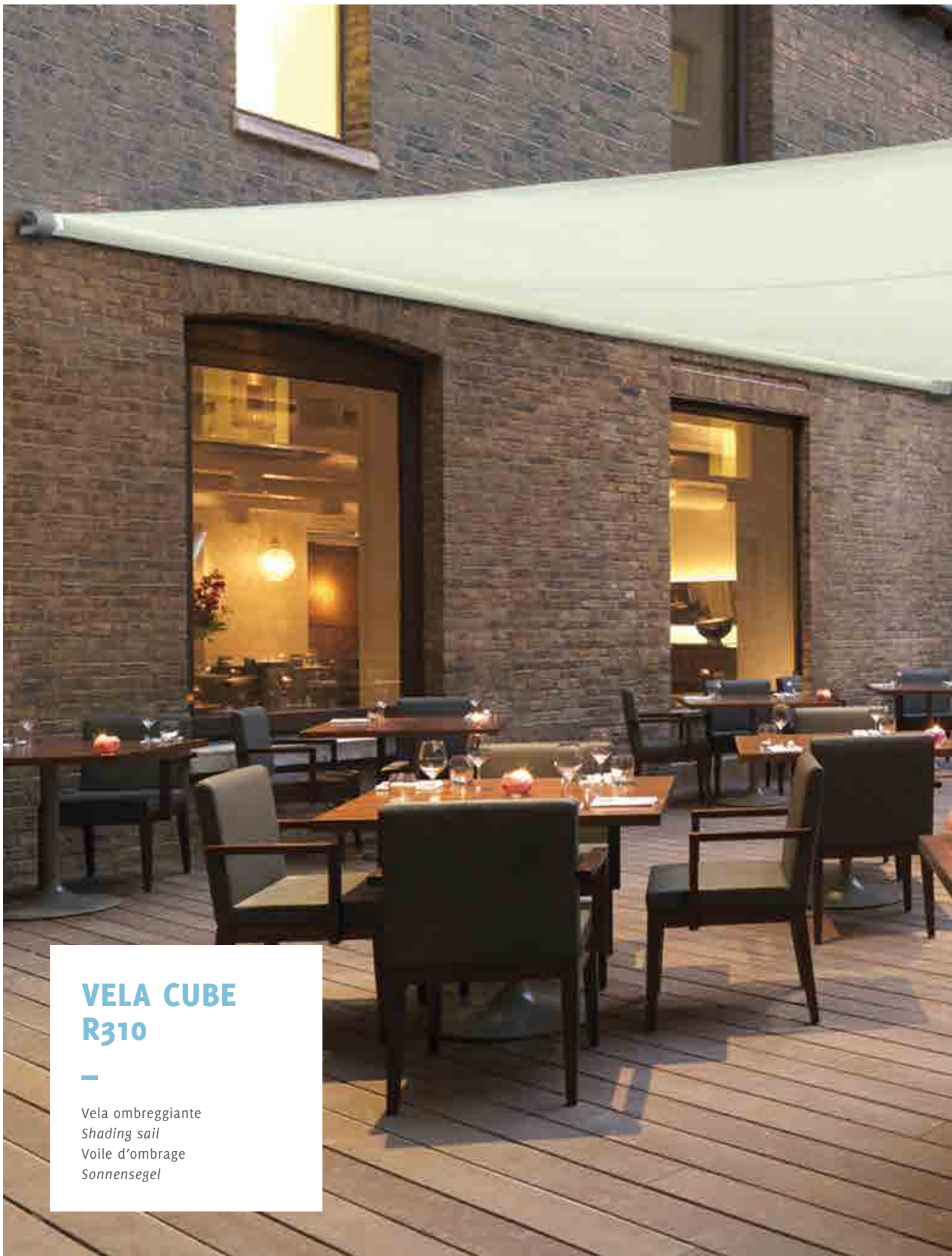

## VELA CUBE R310



Vela ombreggiante  
*Shading sail*  
Voile d'ombrage  
*Sonnensegel*





# VELA DOUBLE R320

Modulo singolo con  
2+2 piantane  
perimetrali + 1 motore  
BT PERGOMOTOR.

*Single form with  
2+2 perimetral poles  
+ 1 motor  
BT PERGOMOTOR.*

Module simple avec  
2+2 poteaux  
périmétriques  
+ 1 moteur  
BT PERGOMOTOR.

*Einzelmodul mit  
2+2 äußeren Stützen  
+ 1 Motor  
BT PERGOMOTOR.*

## DIMENSIONI / DIMENSIONS DIMENSIONS / ABMESSUNGEN

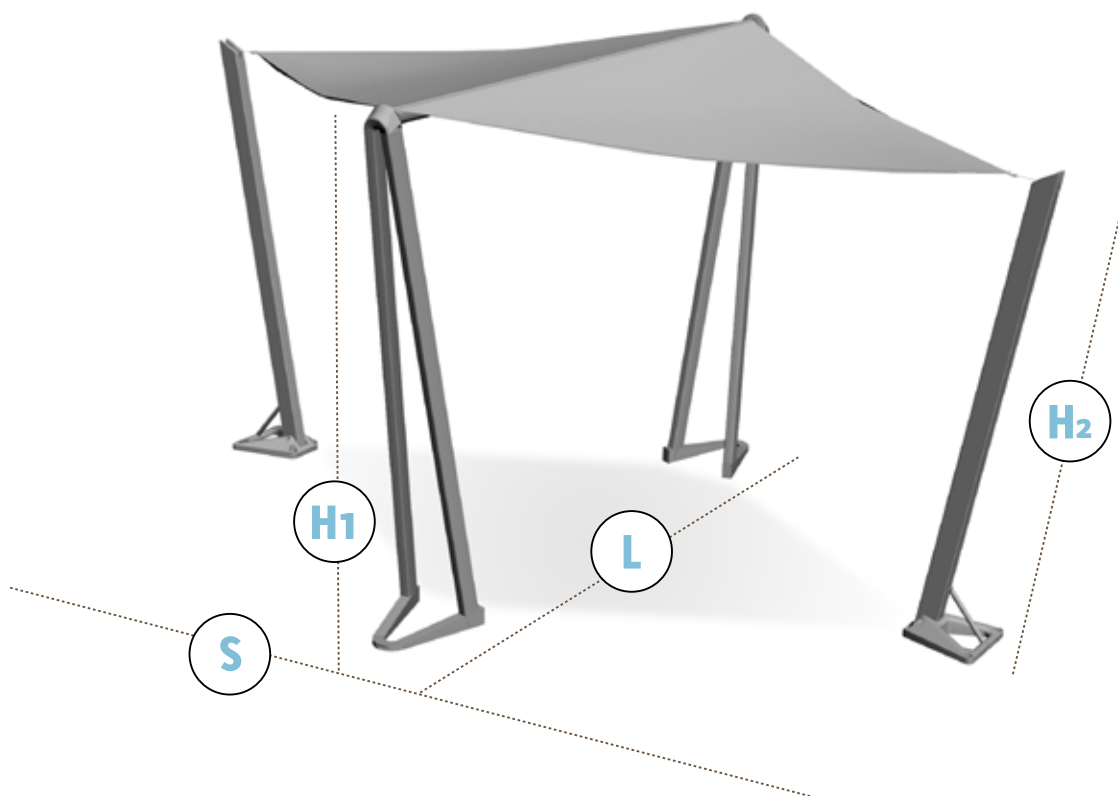

**(L)**

Larghezza / Width  
Largeur / Breite:  
200 >>> 600 cm.

**(S)**

Sporgenza / Projection  
Avancée / Ausladung:  
200 >>> 1200 cm.

**(H1)**

Altezza posteriore  
Back height  
Hauteur arrière  
Hintere Höhe  
300 cm.

**(H2)**

Altezza frontale  
Frontal height  
Hauteur frontale  
Vordere Höhe:  
220 >>> 300 cm.



## VELA DOUBLE R320

—  
Vela ombreggiante  
*Shading sail*  
Voile d'ombrage  
*Sonnensegel*



## DOTAZIONI STANDARD

STANDARD EQUIPMENT / ÉQUIPEMENT STANDARD / SERIENAUSSTATTUNG

---



Staffa attacco parete (R300/R310).  
Wall application bracket (R300/R310).  
Étrier de fixation mural (R300/R310).  
Bügel für Wandbefestigung (R300/R310).



Base a terra.  
Foot.  
Base au sol.  
Bodenelement.





# MOTORI E AUTOMATISMI

## MOTORS AND AUTOMATISM

### MOTEURS ET AUTOMATISMES

#### MOTOREN UND AUTOMATISMEN

---

Vele dotate di motori e telecomandi BT Group o SOMFY, studiati e sviluppati nell'ambito della nostra azienda, in collaborazione con altre società del settore. BT Group propone una gamma completa di accessori offrendo il piacere di possedere telecomandi dal design esclusivo che valorizzano ogni ambiente.

*Sails work by BT Group or SOMFY motors and remote controls, studied and developed in our Factory cooperating with other specific Societies. BT Group offers a complete range of accessories and remote controls with an exclusive design.*

Voiles fonctionnent par moteurs et télécommandes BT Group ou SOMFY, étudié et développé à l'intérieur de notre usine, en collaboration avec autres Sociétés du secteur. BT Group propose une gamme complète des accessoires avec télécommandes personnalisés.

*Sonnensegel mit Motoren und Fernbedienungen BT Group oder SOMFY, in unserer Gesellschaft entwickelt in Zusammenarbeit mit anderen Unternehmen der Branch. BT Group bietet eine komplette Gamme von Zubehöre und Fernsteuerungen.*



somfy



## COLORI STRUTTURA STANDARD

STRUCTURE STANDARD COLOURS

COULEURS DE STRUCTURE STANDARD

STANDARD RAHMENFARBEN

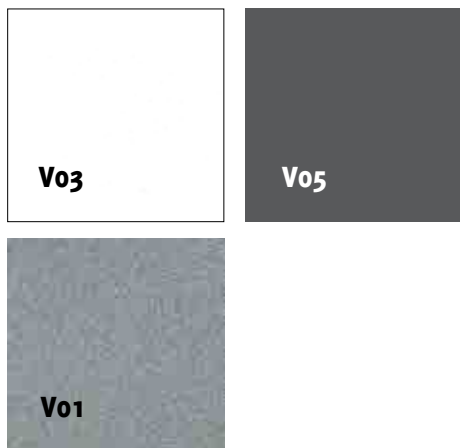

BT Group vi offre la possibilità di scegliere altri colori dalla cartella RAL Europea.

*BT Group gives possibility to choose among other European RAL colours.*

BT Group vous offre la possibilité de choisir autres couleurs du malette RAL européenne.

*BT Group gibt die Möglichkeit, andere Farben aus der RAL Europäichenkarte zu wählen.*

## TESSUTI

FABRICS

TISSUS

GEWEBE



### DACRON

Bianco / White  
Blanc / Weiße

Il DACRON è un tessuto composto da poliestere e viene successivamente resinato per renderlo rigido e impermeabile.

*The DACRON is a fabric made of polyester and is subsequently resin to make it rigid and impermeable.*

Le DACRON est un tissu en polyester et ensuite la résine pour le rendre rigide et imperméable.

*Der DACRON ist ein Gewebe aus Polyester hergestellt und anschließend Harz um starr und undurchlässig zu machen.*



### TEMPOTESTAR

Solo R310 / Only R310  
Seulement R310 / Nur R310

TEMPOTESTAR è la linea di tessuti realizzati con una innovativa fibra 100% Poliestere Tinta in Massa, che lo rendono perfettamente stabile e resistente all'azione dei raggi UV.

*TEMPOTESTAR is the range of fabrics made with an innovative 100% solution dyed polyester fibre, that make perfectly stable and resistant to the action of UV rays.*

Il s'agit de une gamme de tissus réalisé avec une fibre innovatrice 100% polyester coloré, parfaitement stable et résistant aux rayons UV.

*TEMPOTESTAR heißt die Gewebekollektion, die aus einer innovativen Faser hergestellt wird: 100% spinngefärbte Polyesterfaser. Perfekt stabile UV-beständig.*



Protezione solare  
*Sun protection*  
Protection du soleil  
Sonnenschutz



Meccanismo di trazione brevettato  
*Patented traction system*  
Système de traction breveté  
Patentiertes Bespannungssysteme



Marchio CE  
*CE Mark*  
Marquage CE  
CE-Kennzeichnung



Azienda certificata  
*Certification company*  
Entreprise certifiée  
Zertifiziertes Unternehmen



ITALIAN OUTDOOR

[www.btgroup.it](http://www.btgroup.it)

BT Group si riserva il diritto di modificare in qualsiasi momento e senza preavviso i dati del presente stampato. Le foto sono puramente indicative e non costituiscono nessun vincolo contrattuale. Ogni riproduzione, anche se parziale, è vietata.

*BT Group reserves the right to change these printed datas at any time without any warning. Pictures are purely indicative and don't constitute any contractual obligation. Any part, even if partial, can't be reproduced.*

BT Group se réserve le droit de modifier à tout moment et sans préavis les données de cette brochure. Les photos sont à titre purement indicatif et ne constituent aucune obligation contractuelle. Toute reproduction, même partielle, est interdite.

*BT Group behält sich das Recht vor, zu jedem beliebigen Zeitpunkt und ohne vorherige Ankündigung Änderungen an den Daten der vorliegenden Veröffentlichung vorzunehmen. Die abgebildeten Fotografien dienen lediglich der Veranschaulichung und stellen keinerlei vertragliche Verpflichtungen dar.*

